

<i>Feature</i>		<i>Beschreibung</i>	
1	Konstruktion	STYLE 68 ALU	
2	Material	<ul style="list-style-type: none"> - Kiefer mit Mikrozinken, - Lasierete Kiefer (durchgehend), - Meranti, 	
3	Beschlagsoptionen	<ul style="list-style-type: none"> - kipp, dreh, dreh-kipp, kipp-dreh, - Stulp (Kämpfer) mit Espagnolette, - Oberlichten-Schließer (kipp) mit Hebel (Hau-Tau), - Sicherheitsbeschläge RC1 , RC2, - Schiebe-kipp Beschlag, - Balkontür mit niedriger Aluschwelle, - Verdecktliegende Beschläge, - Umkehrfunktion des Griffes (Kipp vor Drehfunktion), Balkontür nach außen öffnend. 	
4	Mögliche Formen	<ul style="list-style-type: none"> -rechtwinkelig, - dreieckig, - trapez, - rund, - bogen, 	
5	Maß	<p>Breite des Flügels: 332 - 1547mm Höhe des Flügels: max 2600mm.</p> <p>Proportion Breite/Höhe des Flügels - max 1,5. maximales Gewicht des Flügels 130kg - (kipp, dreh-kipp). maximales Gewicht des Flügels 50kg - (dreh). maximales Gewicht 80kg - (Dreieck-, Rund-, Bogen-Element) Gewicht des Glases 1m² mit einer Stärke von 1mm = 2,5 kg</p>	
6	Verglassung	Dicke des Glaspaketes bis zu 31 mm- Bogenfenster, Rechtwinkligefenster	
7	Endgültige Beschichtung (Finish)	Lackierung mit Deckfarben oder mit Transparentfarben	
8	Farben	<ul style="list-style-type: none"> - Deckfarbe RAL 9016 (weiß) - Lasuren: Kiefer TM367, Afromosie TM4239, Mahagoni TM1530, Palisander TM1705, Teak TM1703, Zypresse TM5207, Wenge TM9012, Nuss TM1515, Graphit TM1504, Natur lasur - andere Optionen entsprechend RAL-Palette, 	
9	Wetterschenkel	<p>Thermisch optimierte Regenschutzschiene und Wetterschenkel am unteren Teil des Flügels</p> <p>weiß, braun, olive</p> <p>- andere Optionen nach Wunsch entsprechend RAL-Palette,</p>	
10	Beschlagsabdeckungen	<p>Beschläge : Beschlagsabdeckungen weiß oder olive</p> <p style="text-align: center;">andere Optionen entsprechend RAL-Palette</p>	
11	Sprossen	<ul style="list-style-type: none"> - Konstruktive Sprossen 80mm - Wienersprossen 12x24mm - Glasinnenliegende Sprossen 	

<i>Feature</i>		<i>Beschreibung</i>	
12	Breite des Konstruktionselementes	Breite der Rahmenhölzer 80mm, Breite des Rahmenelementes 83mm,	
13	Fensterlüfter	Im Flügel integriert: a) Aereco EMM b) Trimvent 90 HL c) Aereco EXR Fensterlüfter im Flügel-Top integriert (nicht sichtbar) im Rahmen: a) Trimvent S13 b) Aereco EMM c) Ventair	
14	Zusätzliche Optionen	- Stockverbreiterung - Kopplung - 90° Eck-Kopplung, - 135° Eck-Kopplung, - Schwellen: a) Fensterbankanschluss außen + innen 11x 30mm, b) Fensterbankanschluss innen 11x30mm, c) Fensterbankanschluss außen 12x30 mm, d) Fensterbankanschluss außen + innen 11x14mm , e) Fensterbankanschluss außen 12x30 mm + Fräsung 10x10mm innen, f) ohne Fräsung, - Deckleiste,	
15	Silizium	- transparent,	

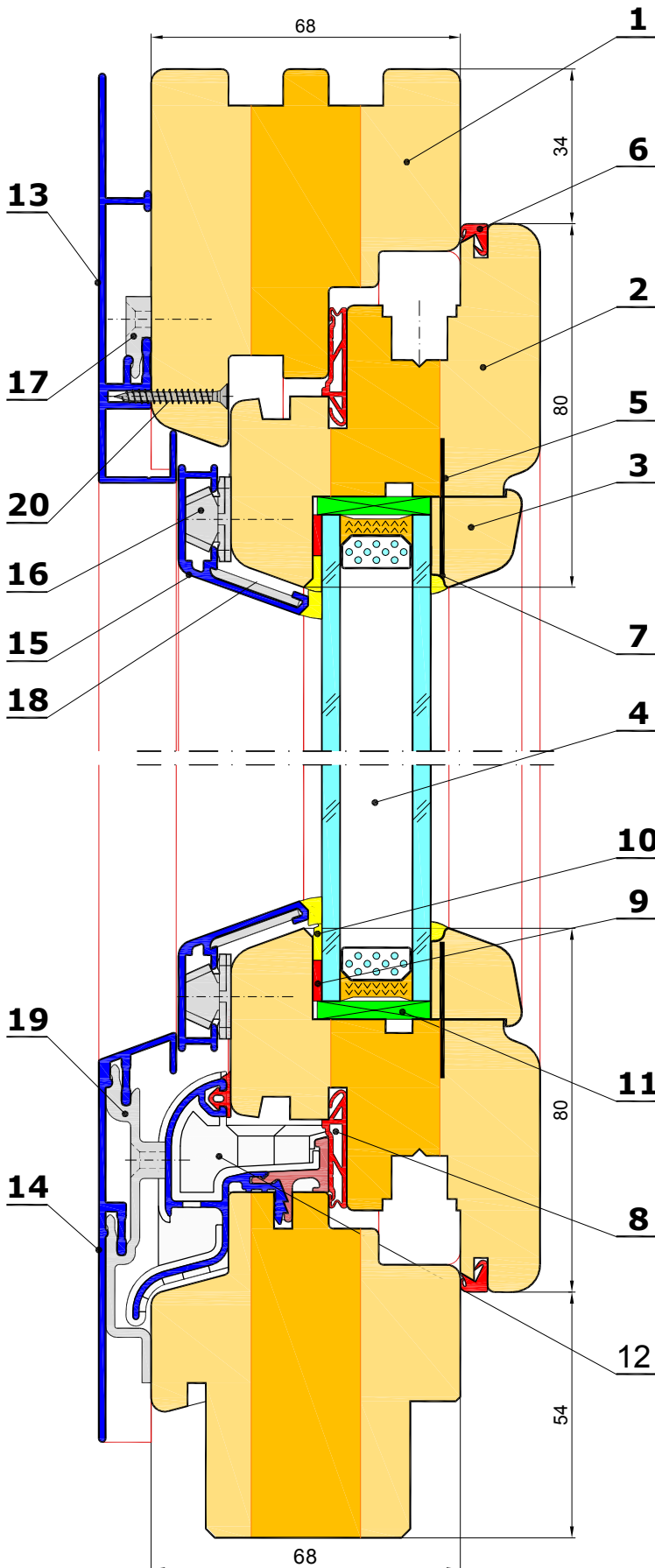

Kombination der Elementen:

- 1 - Rahme des Fensters- Holz
- 2 - Flügel der Fenster - Holz
- 3 - Glasleiste - Holz
- 4 - Thermoscheibe
- 5 - Stahlstift SK 330 (1,1 x 30mm)
- 6 - Randdichtung TPS -SP 33 Deventer
- 7 - Silikon
- 8 - Falzdichtung TPE - SV 180 Deventer
- 9 - Neoprendichtung
- 10 - Silikon nach DIN 1845 T.2 (Gruppe E)
- 11 - Unterlage aus hartem PVC - 3,5x25x100mm
- 12 - Alu-Wetterschenkel- LPRS 22 Z
Komplettes Wetterschenkel-Set LPRS 22 Z
- 13 - 13-Aluminiumschale am Rahmen (seitlich)
- 14 - Aluminiumschale am Rahmen (unten)
- 15 - Alu Flügelprofil
- 16 - Montageklipps aus Kunststoff
- 17 - Stahlverbindungshalterung für Aluminiumschale
- 18 - Ausgleichsversteifung am Rahmen für Aluminiumschalen
- 19 - Halterungsklipp (am Wetterschenkel) für Aluminiumschale
- 20 - Senkschraube aus Nirostahl

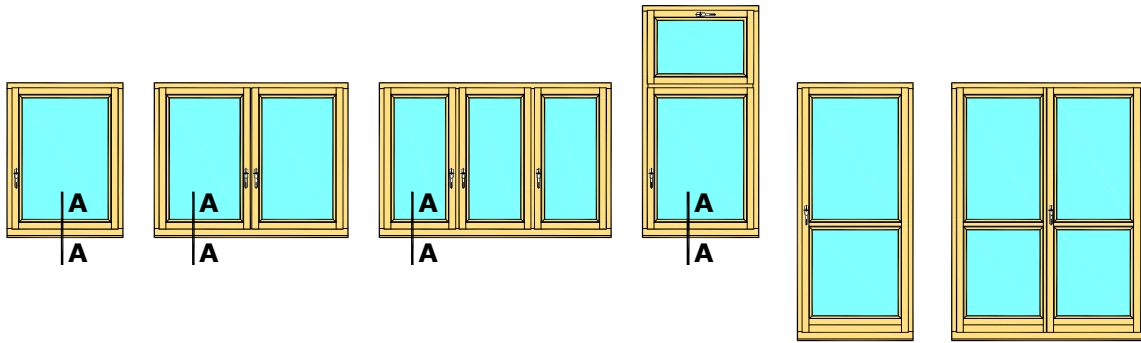

A-A

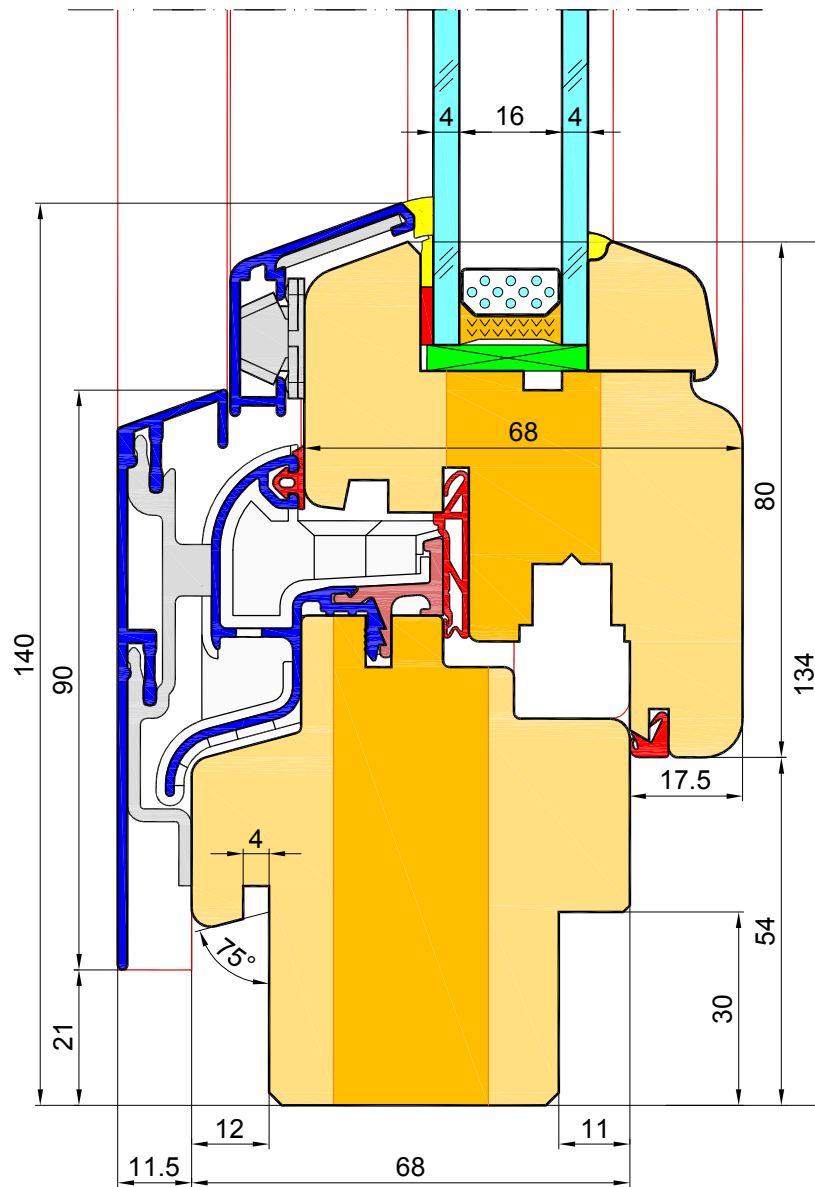

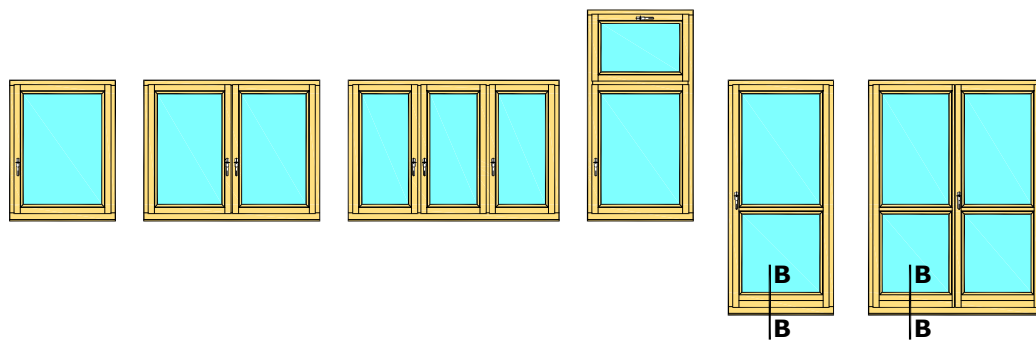

B-B

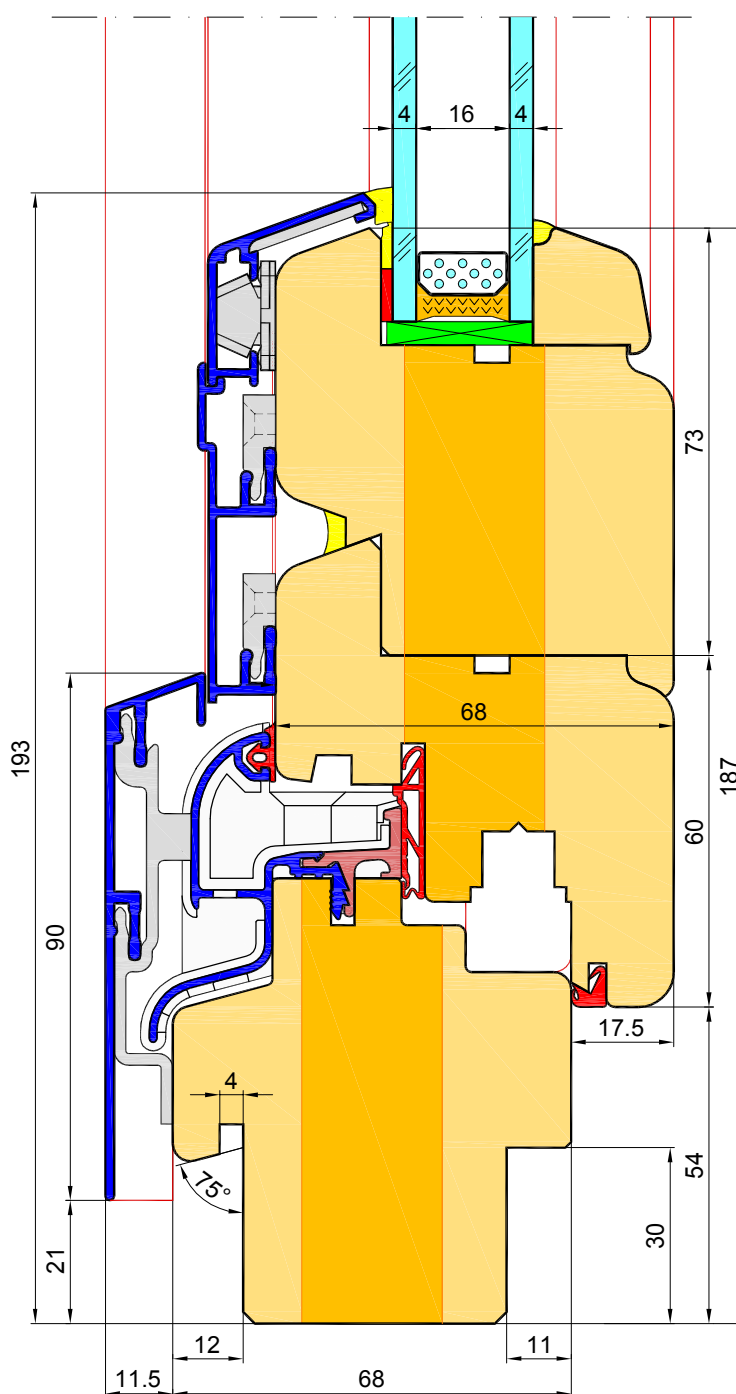

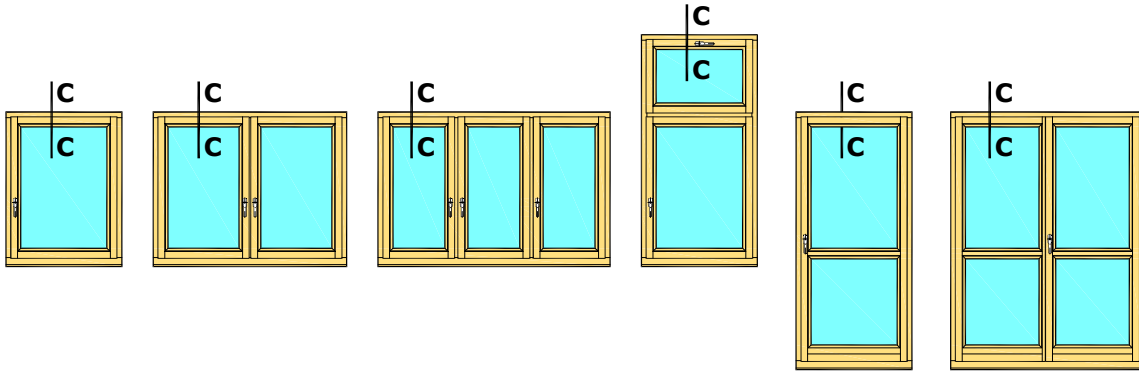

C-C

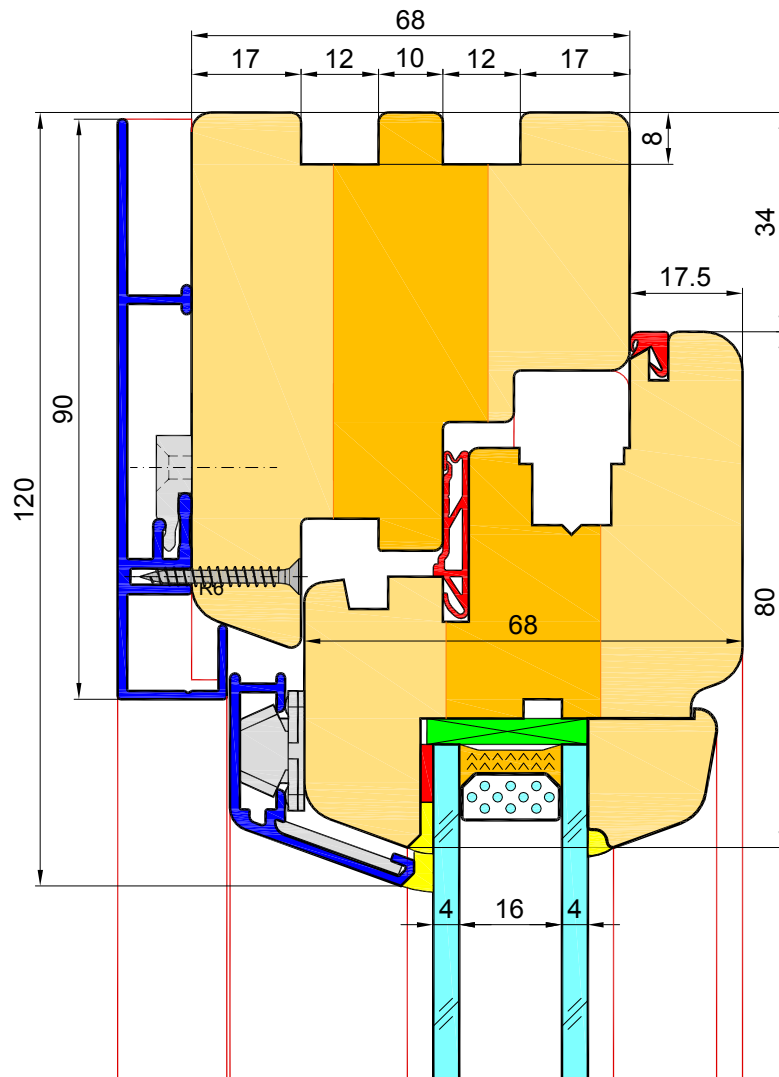

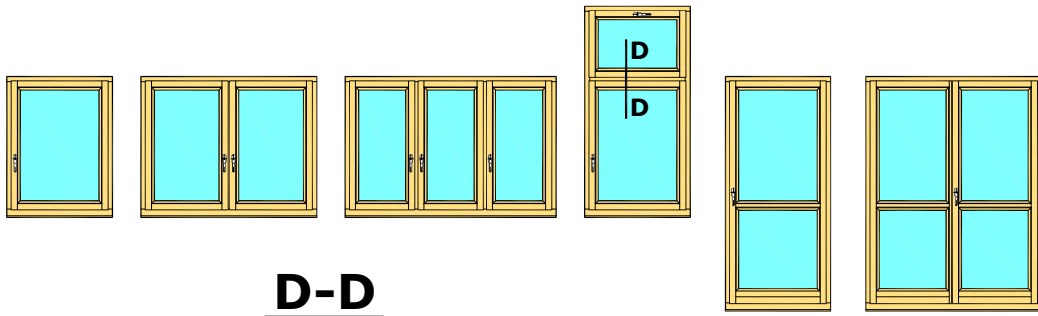

D-D

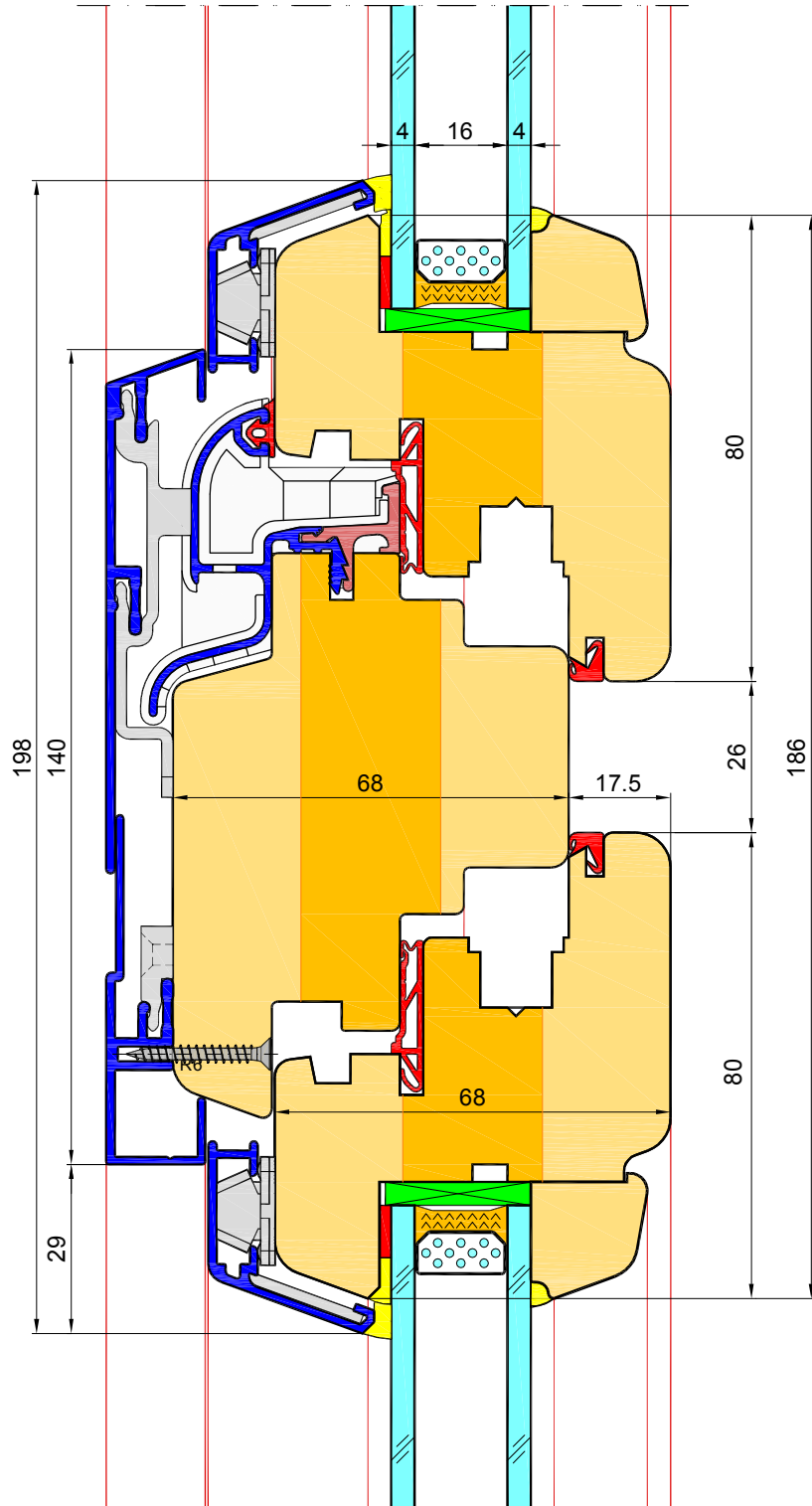

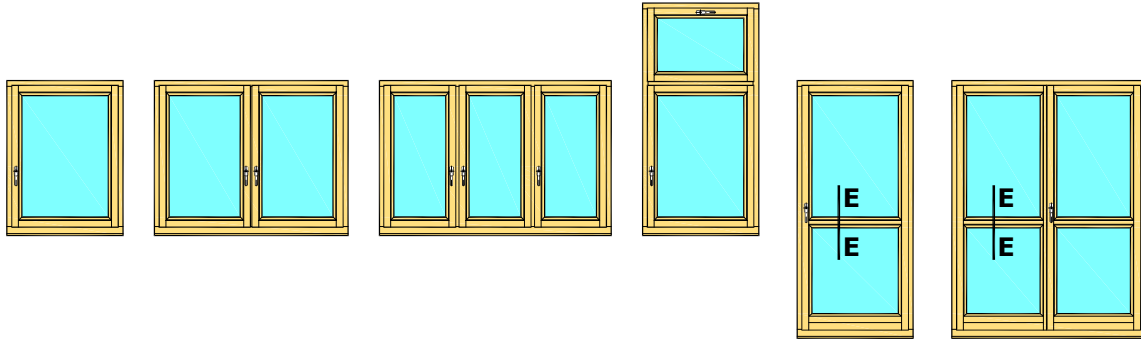

E-E

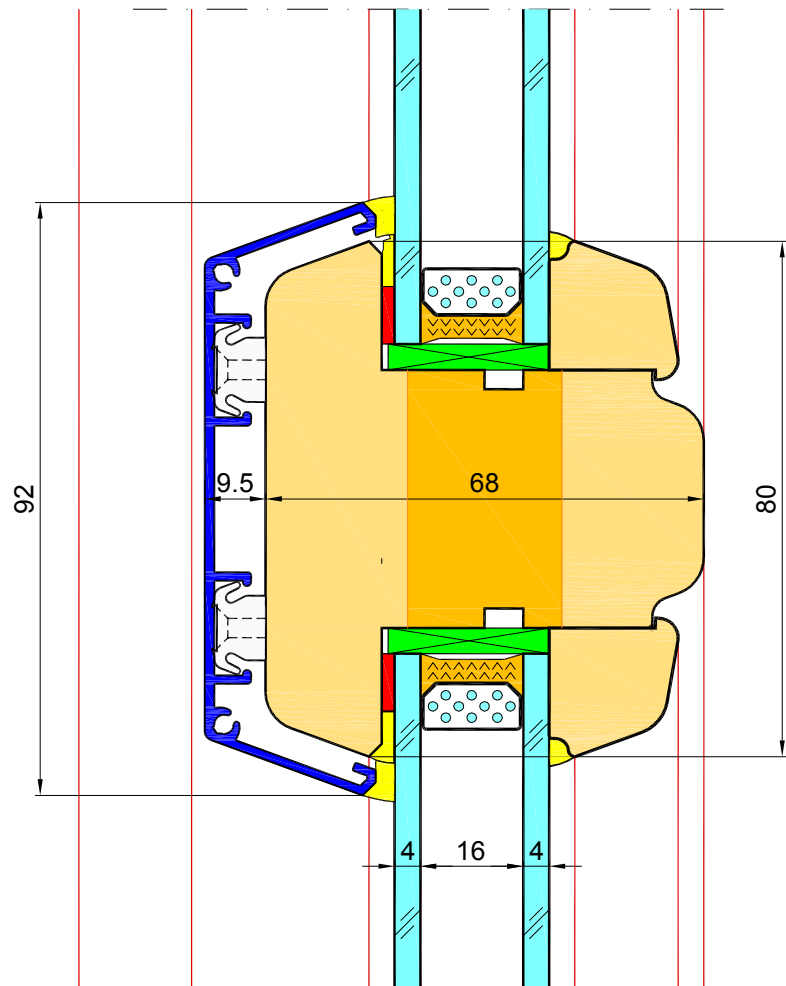

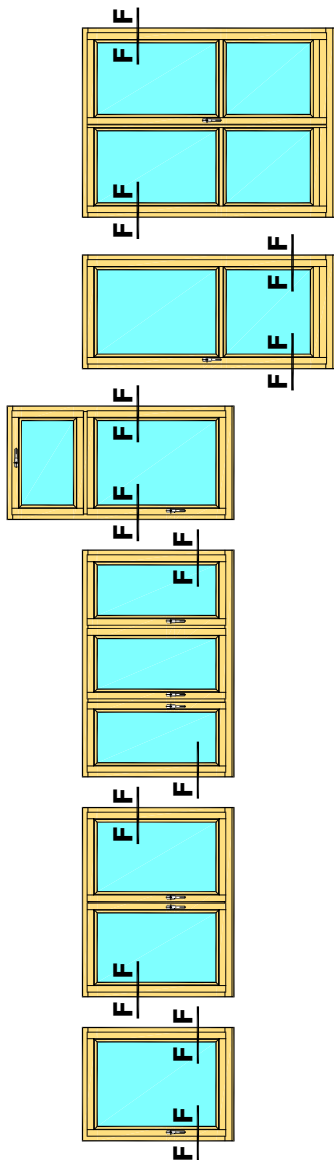

F-F

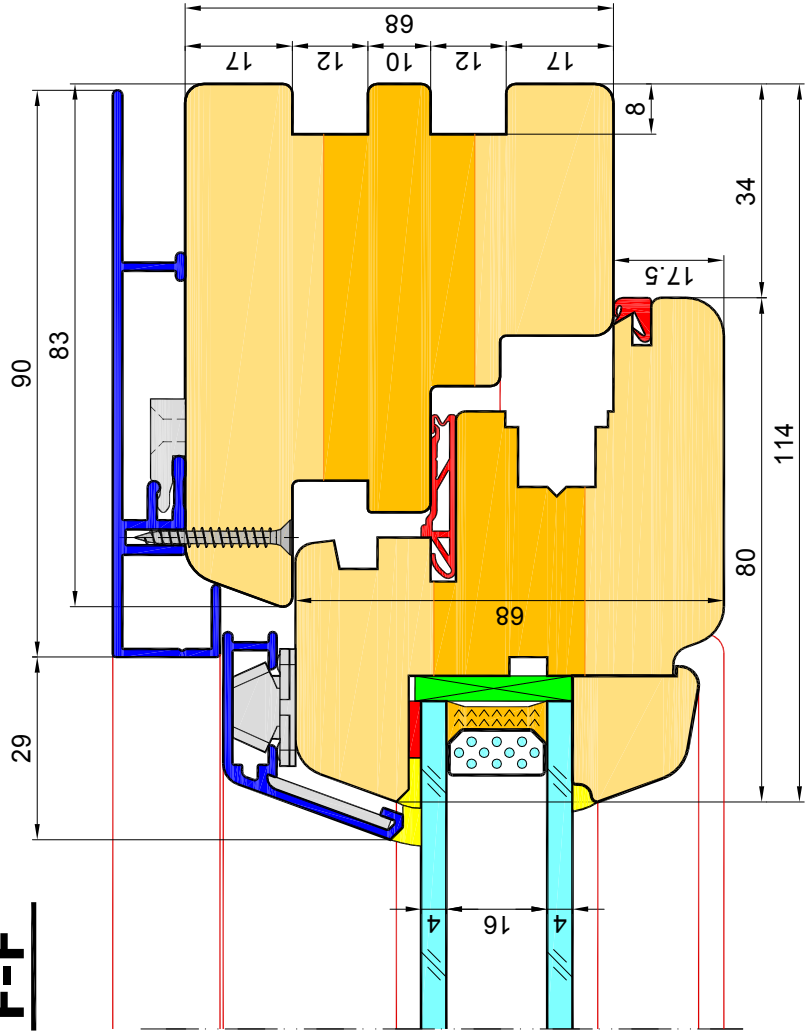

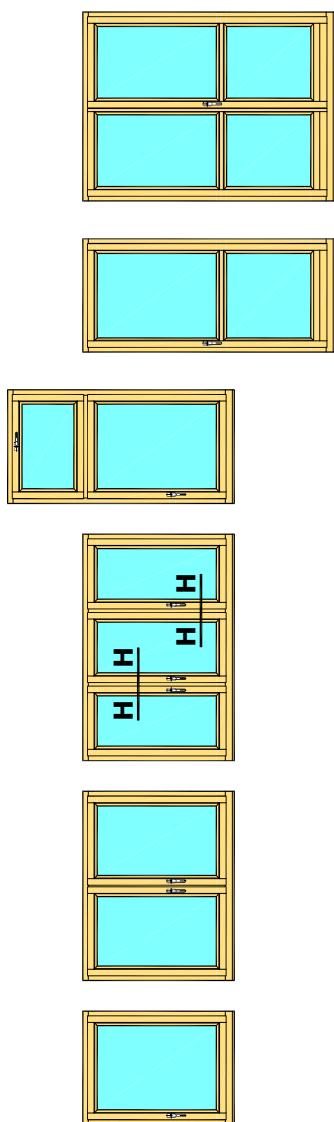

H-H

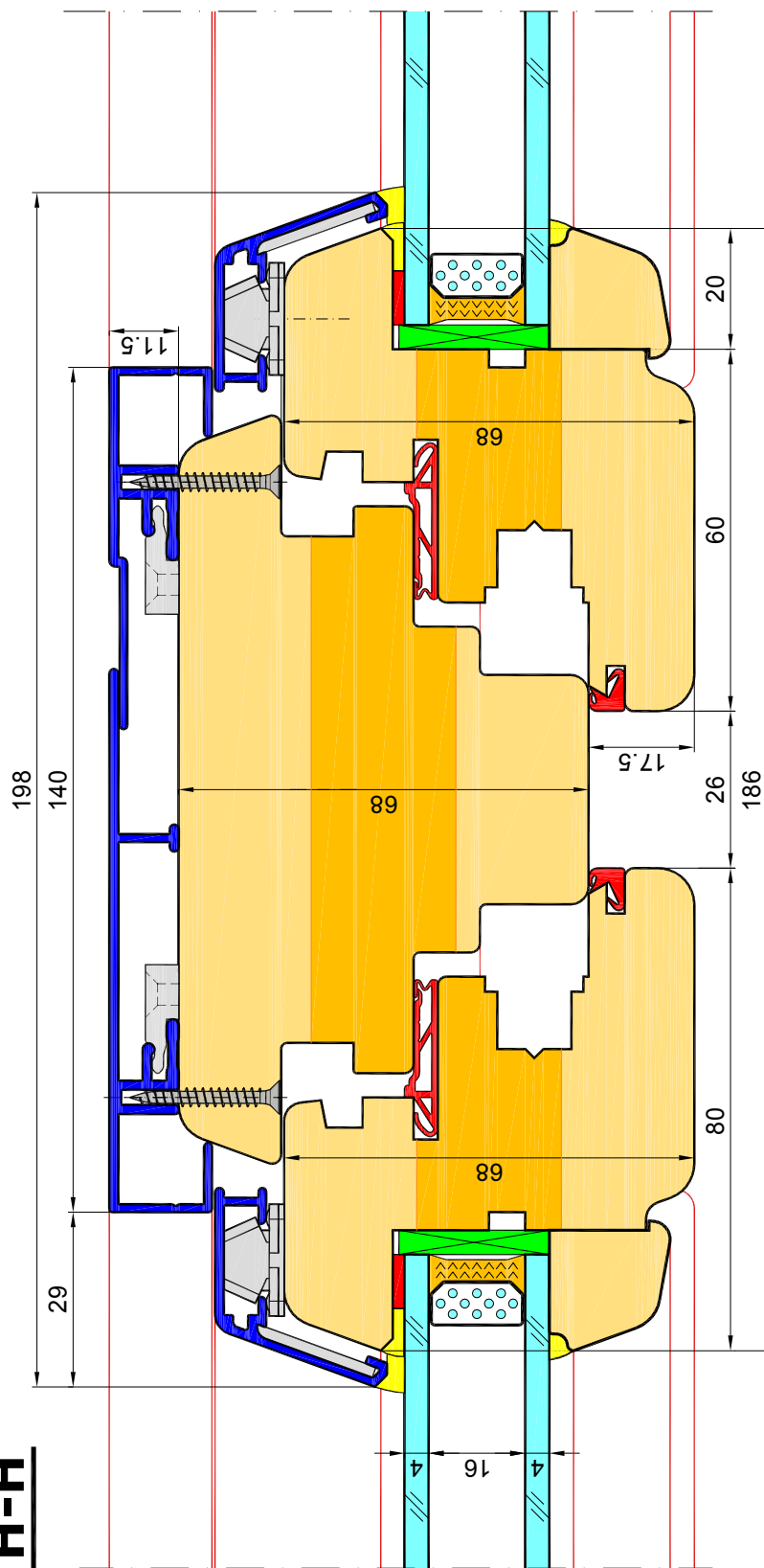

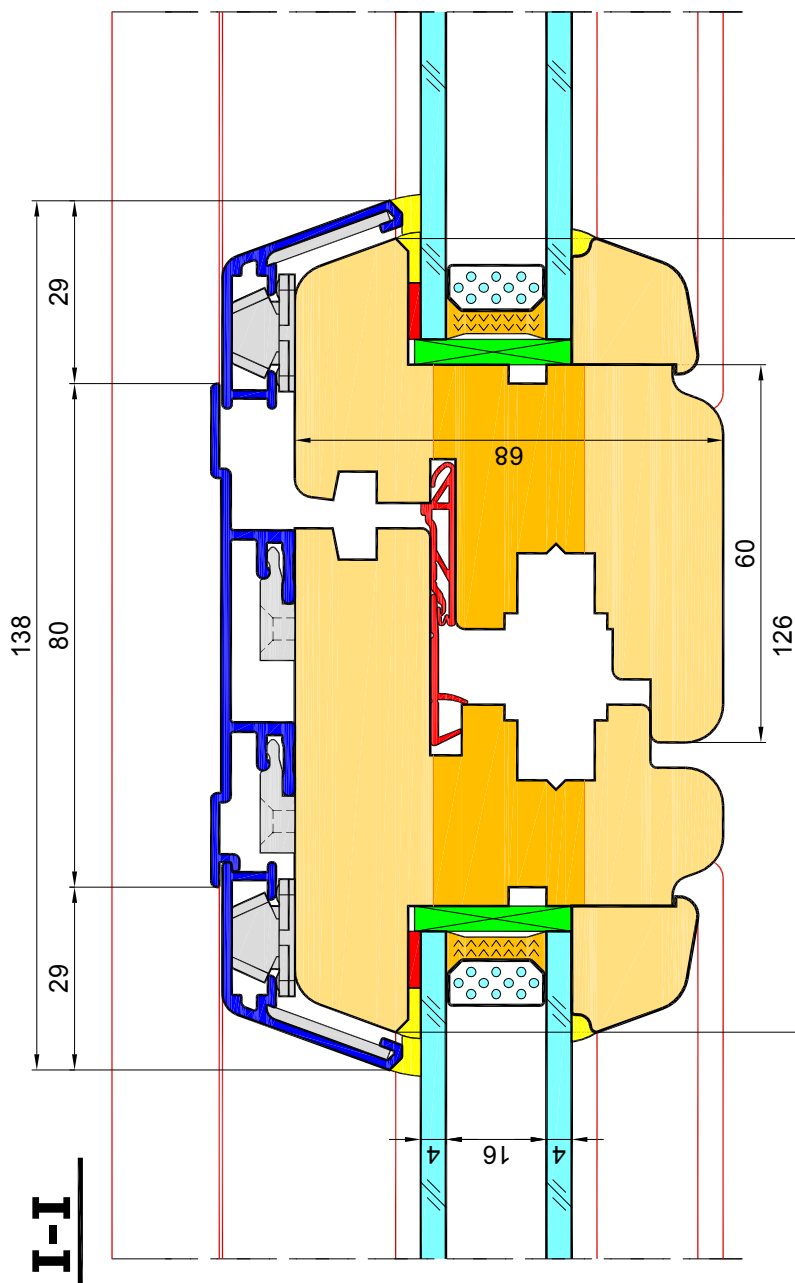
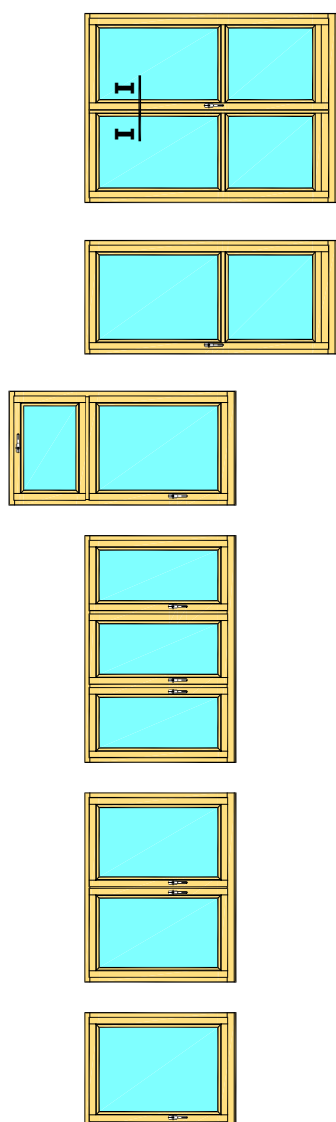

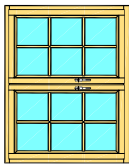
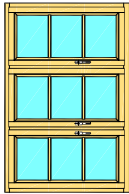
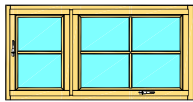
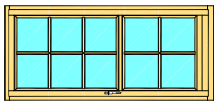
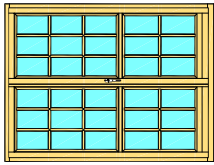
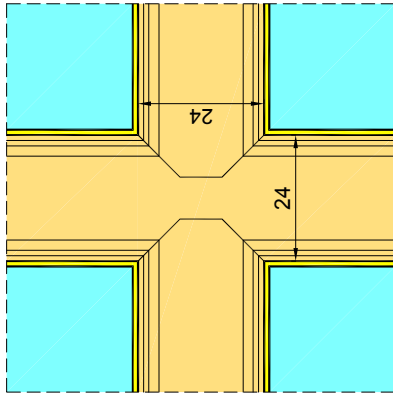

Szczegół - 1

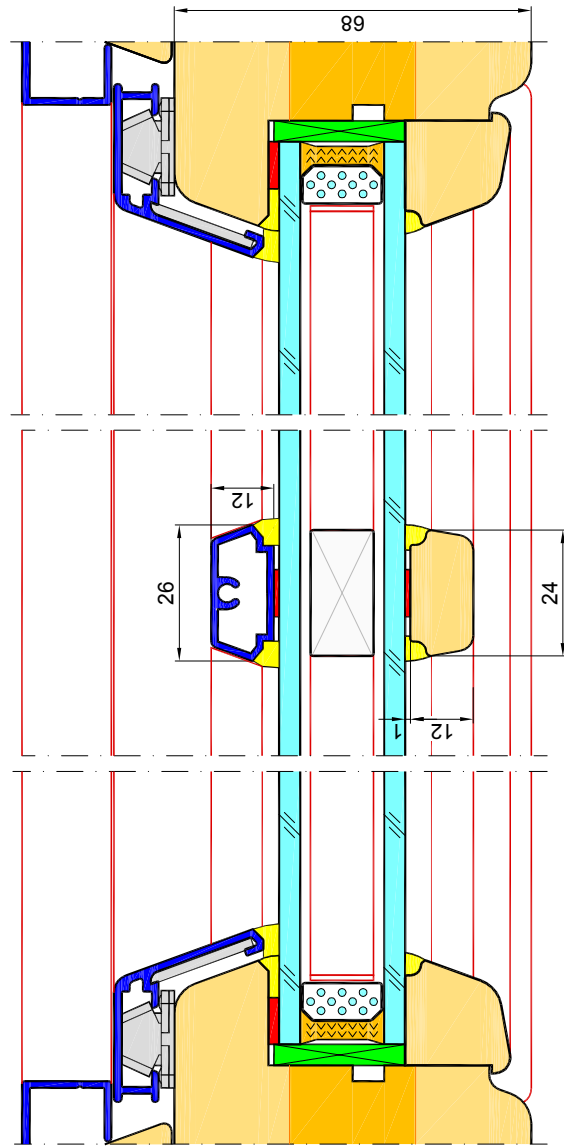
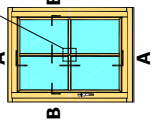

B-B

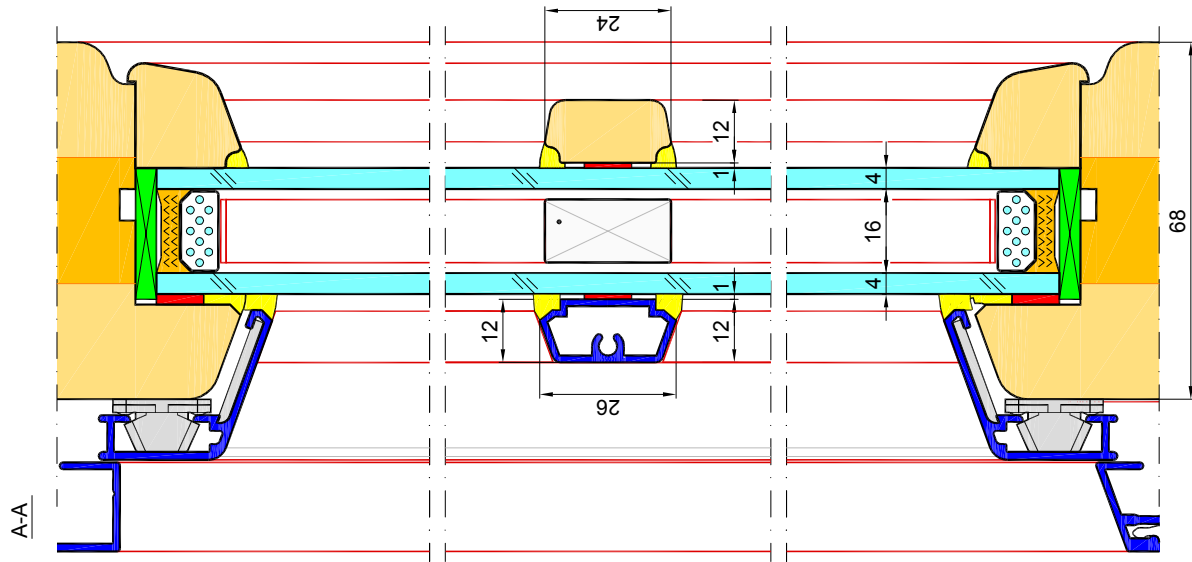

A-A

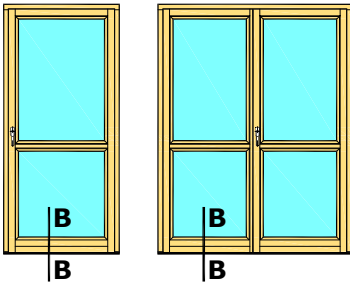

B-B

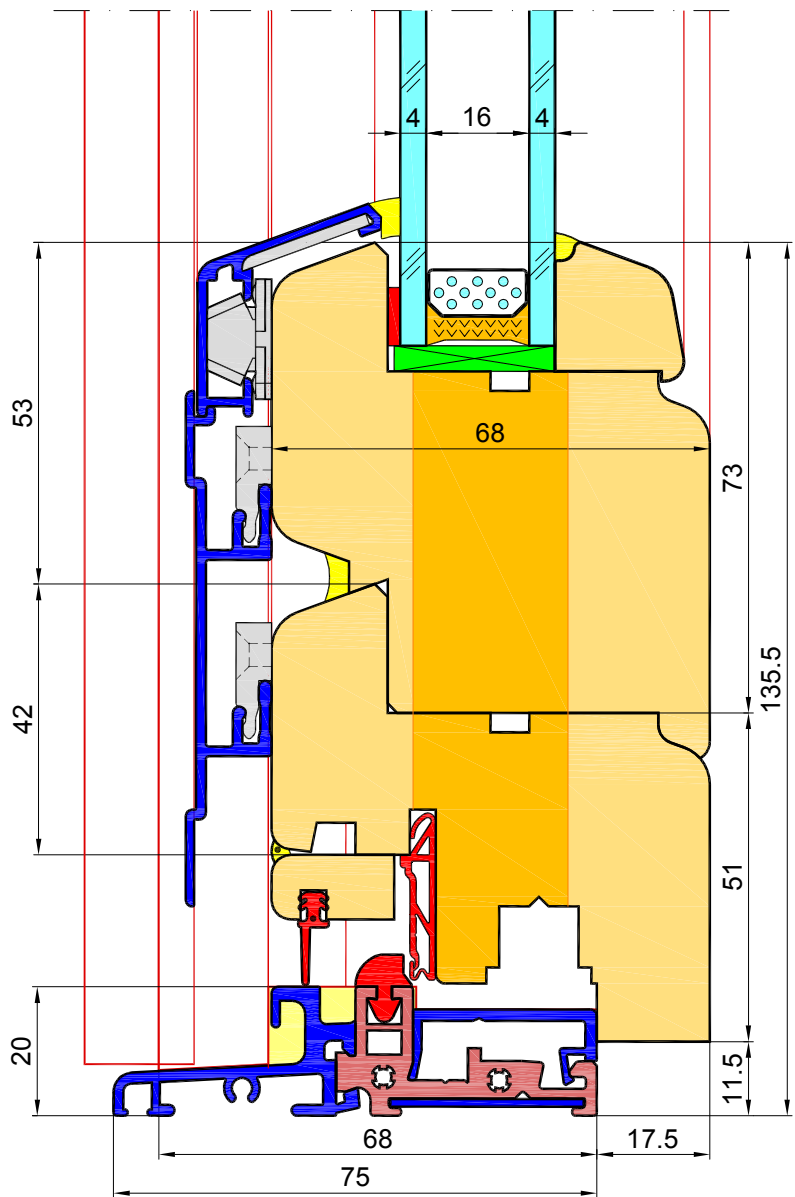

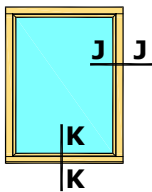

K-K

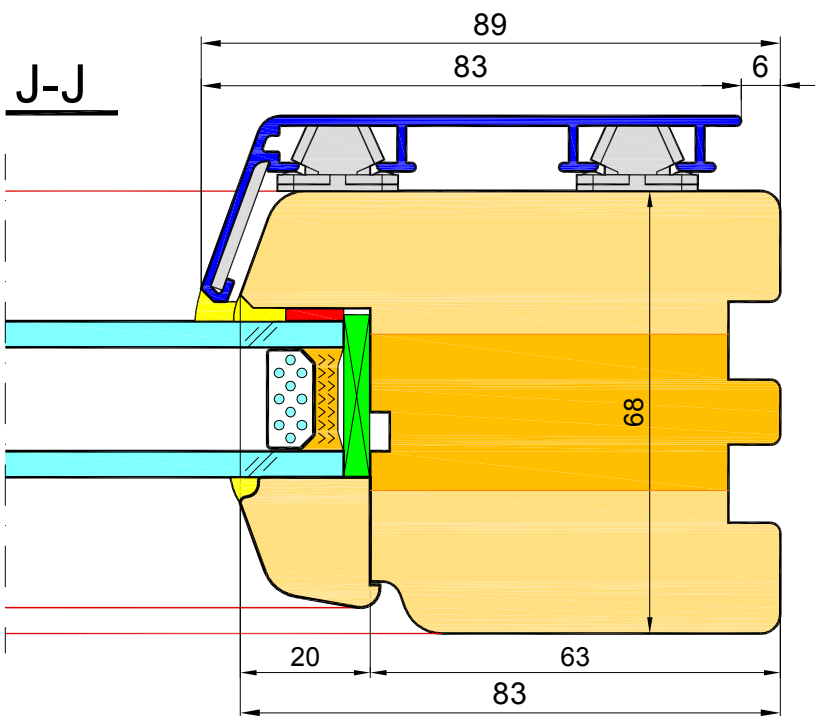
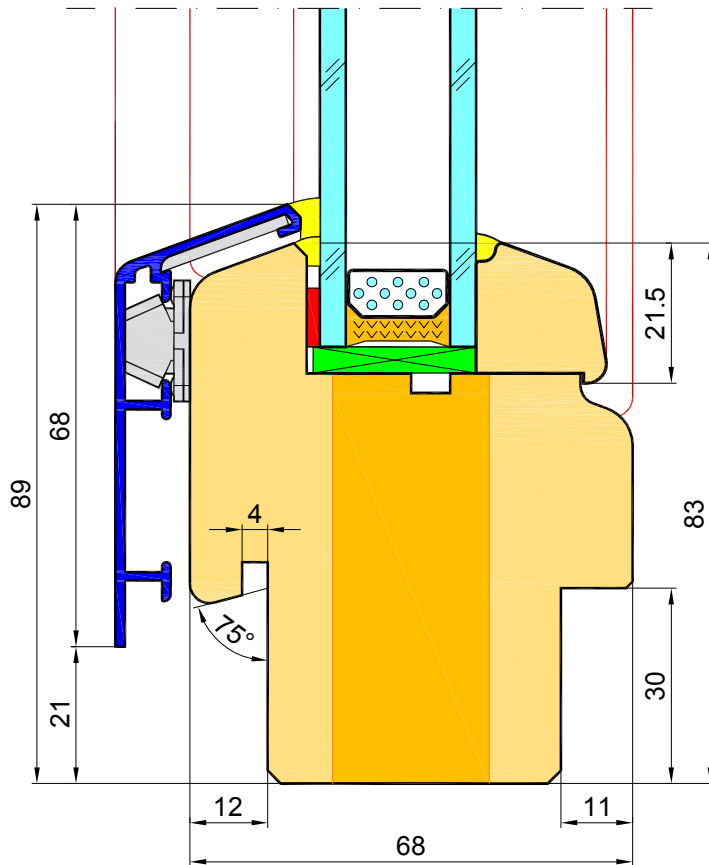

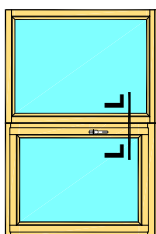
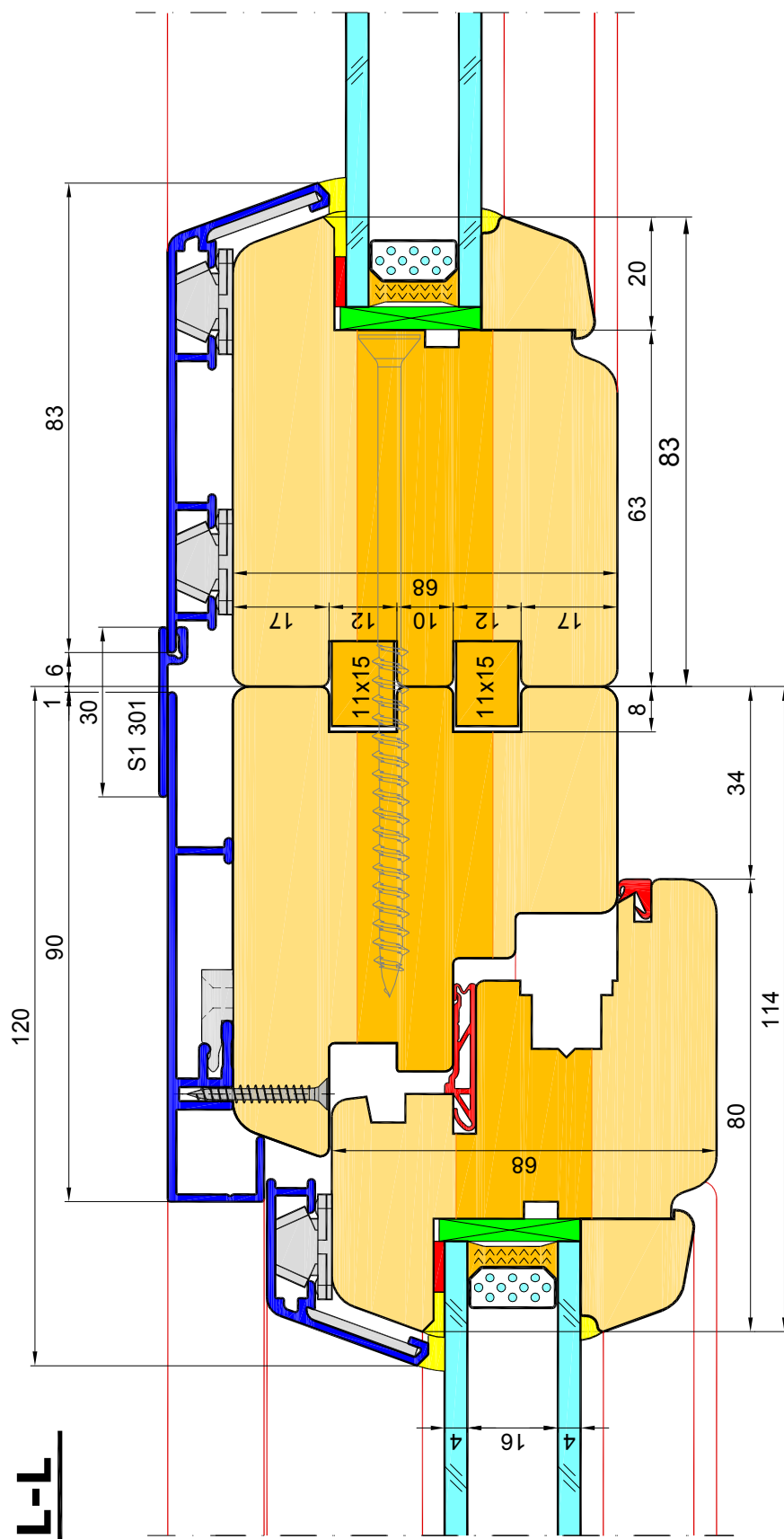

L-L

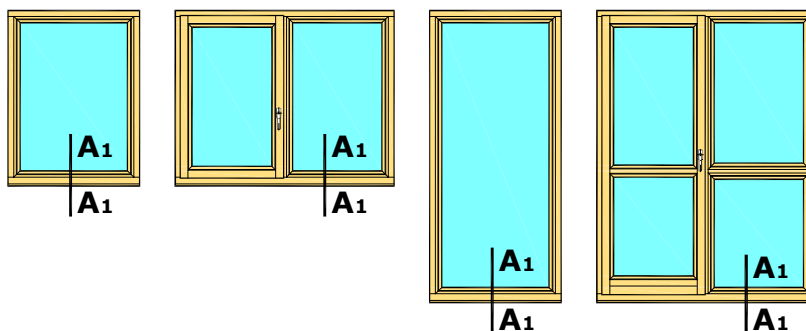

A1-A1

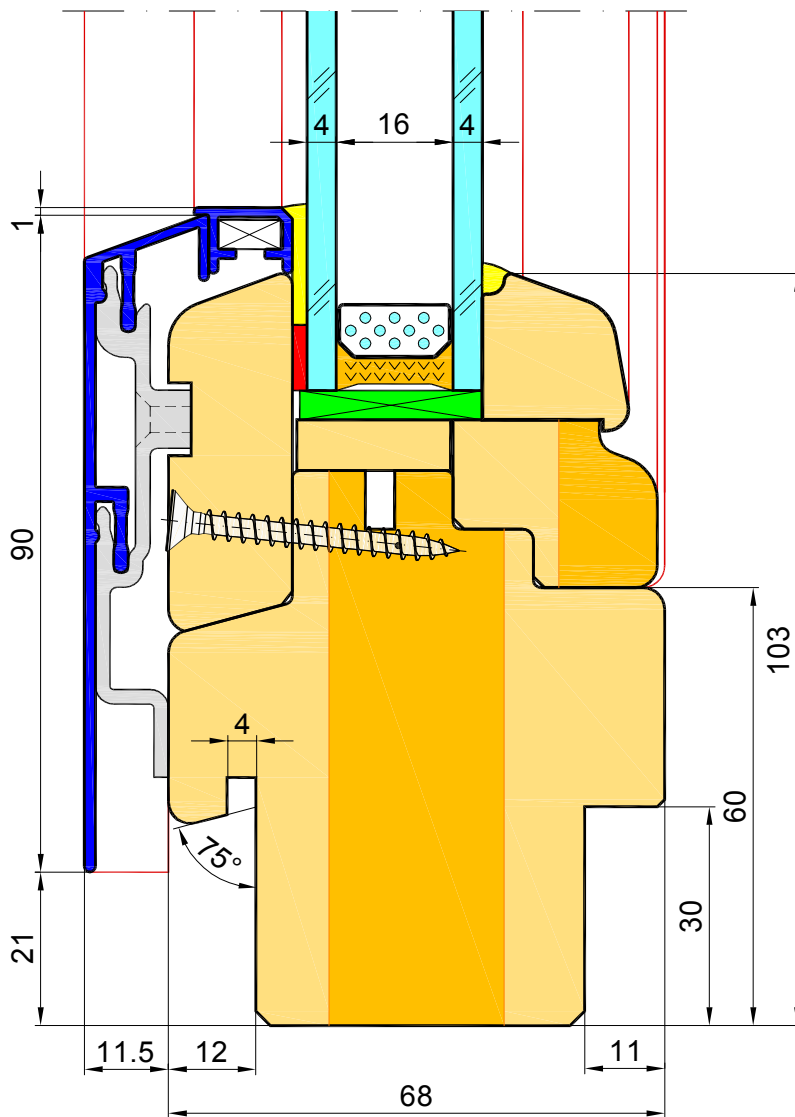

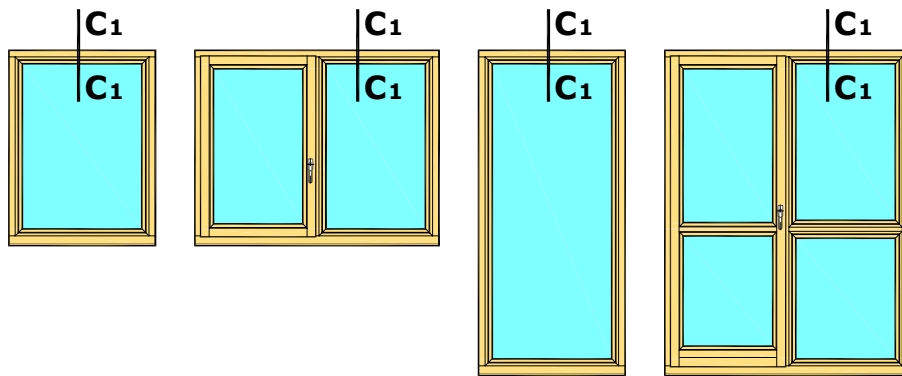

C1-C1

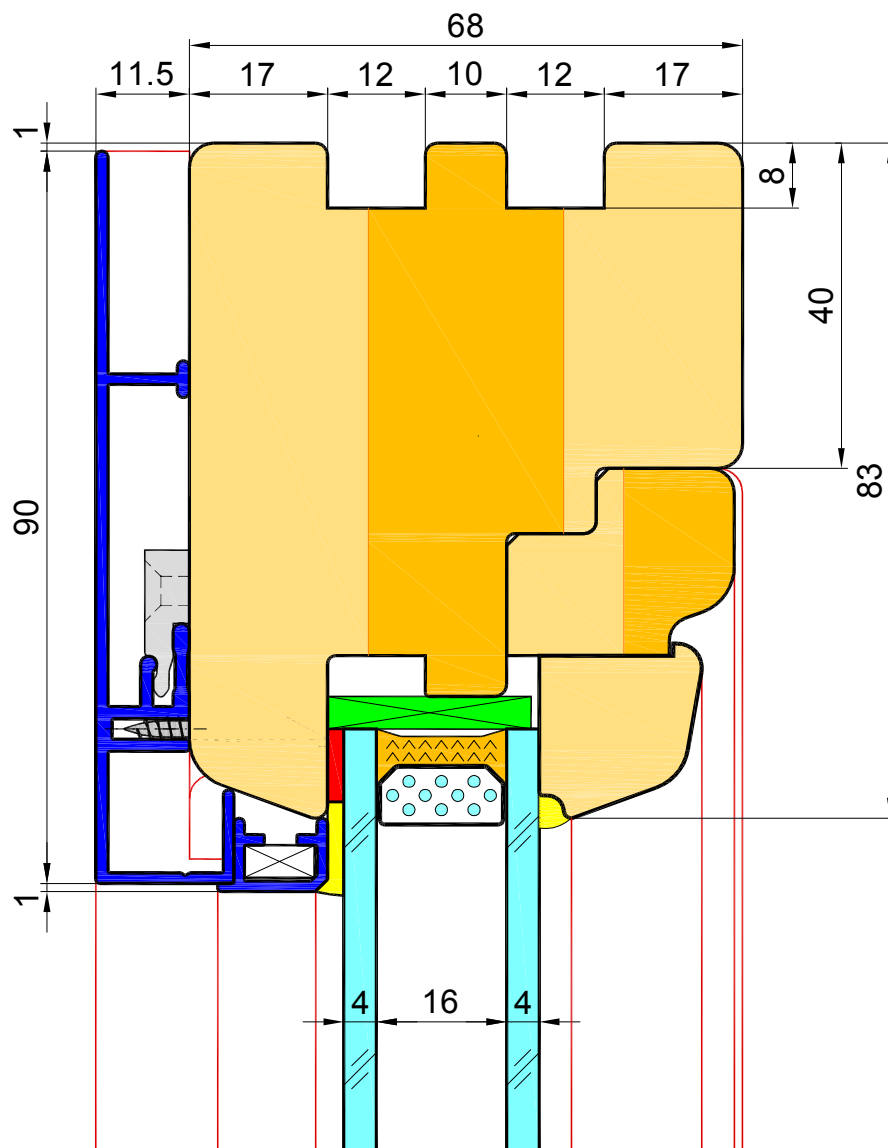

G1-G1

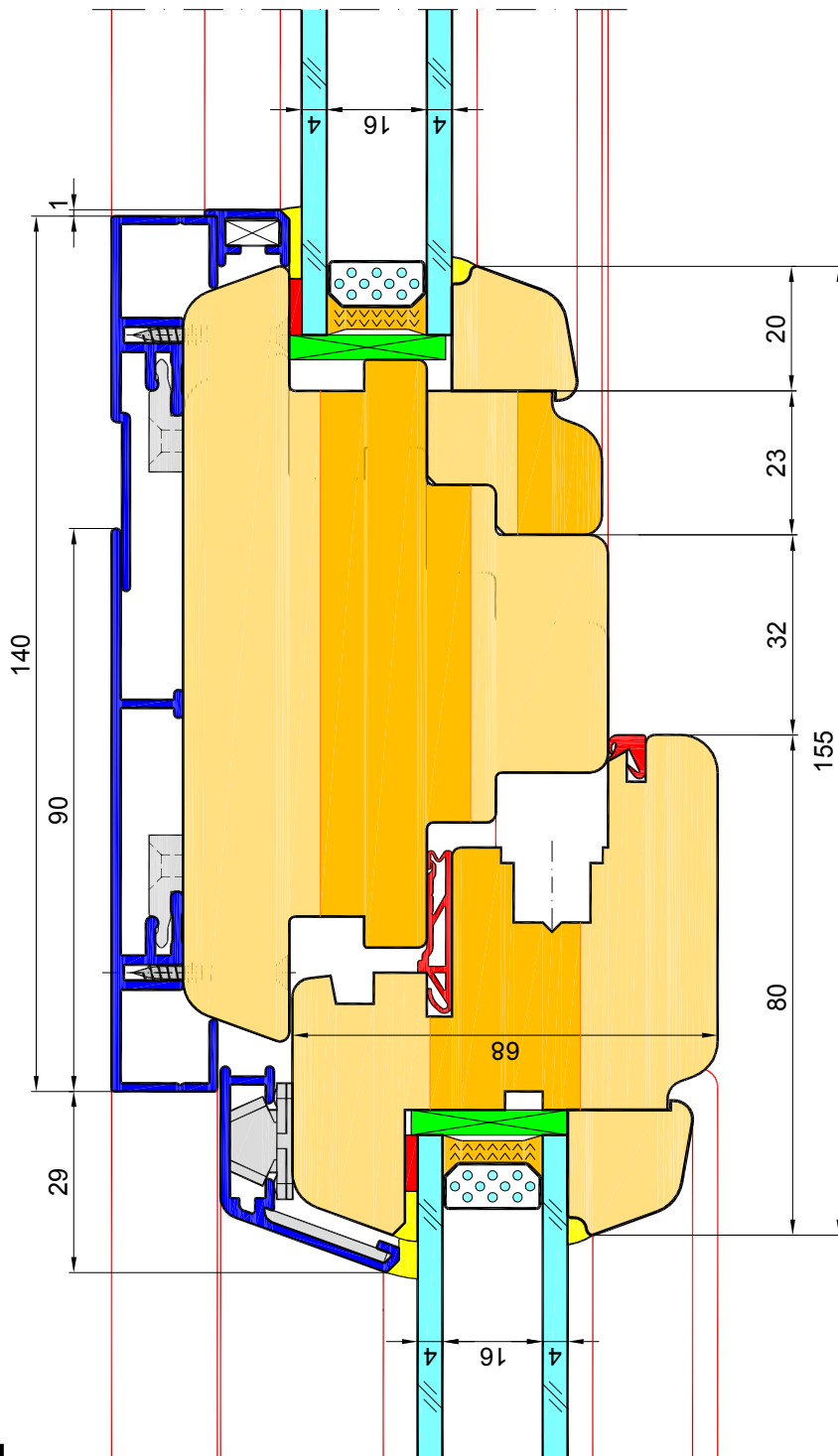
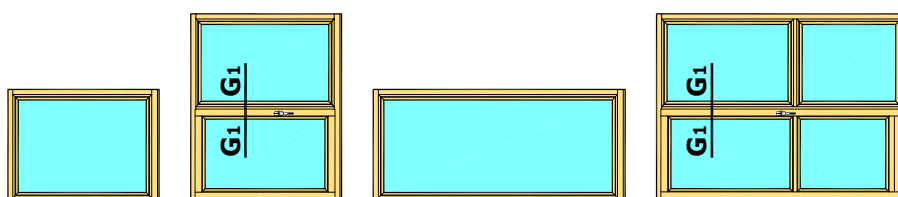

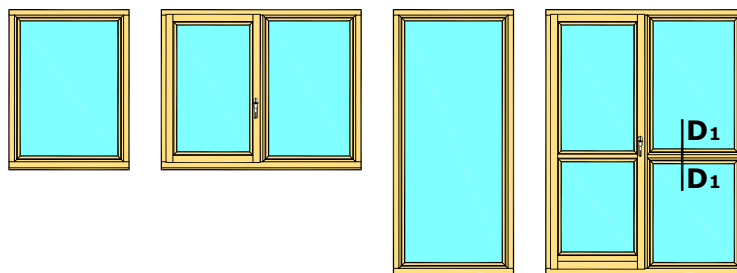

D1-D1

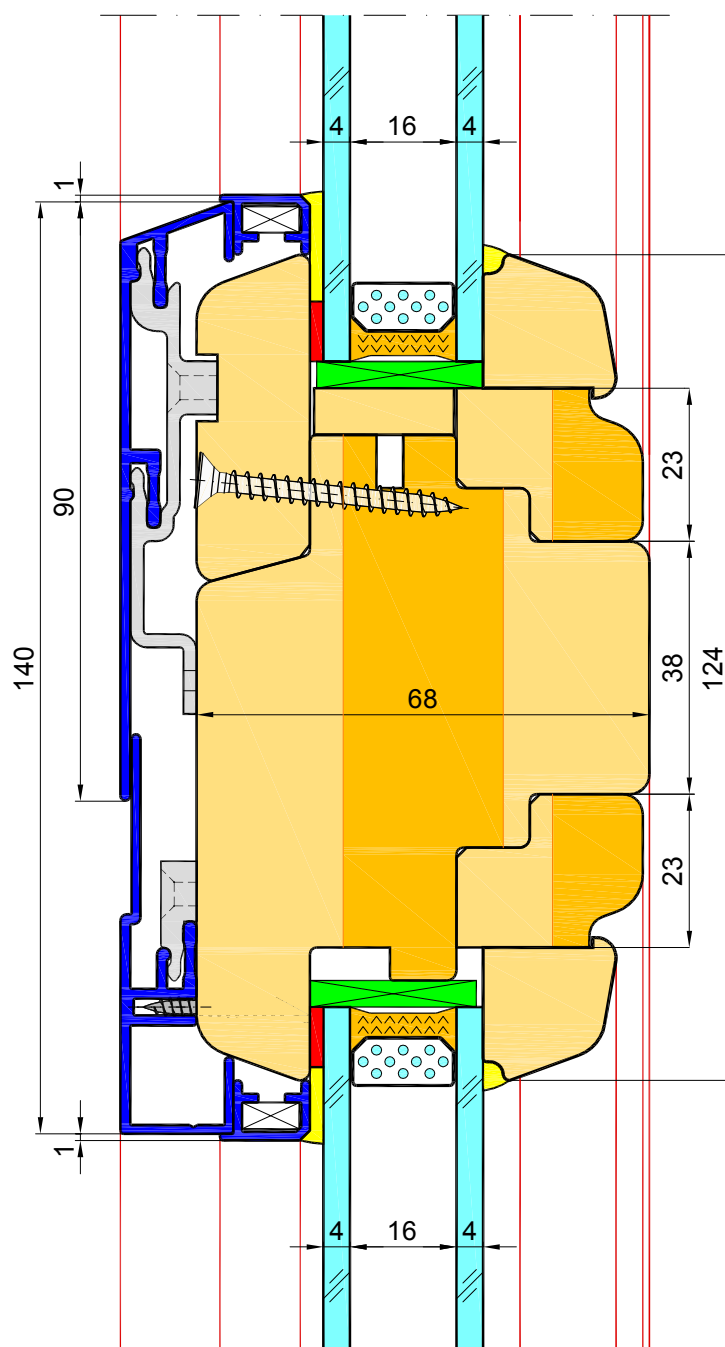

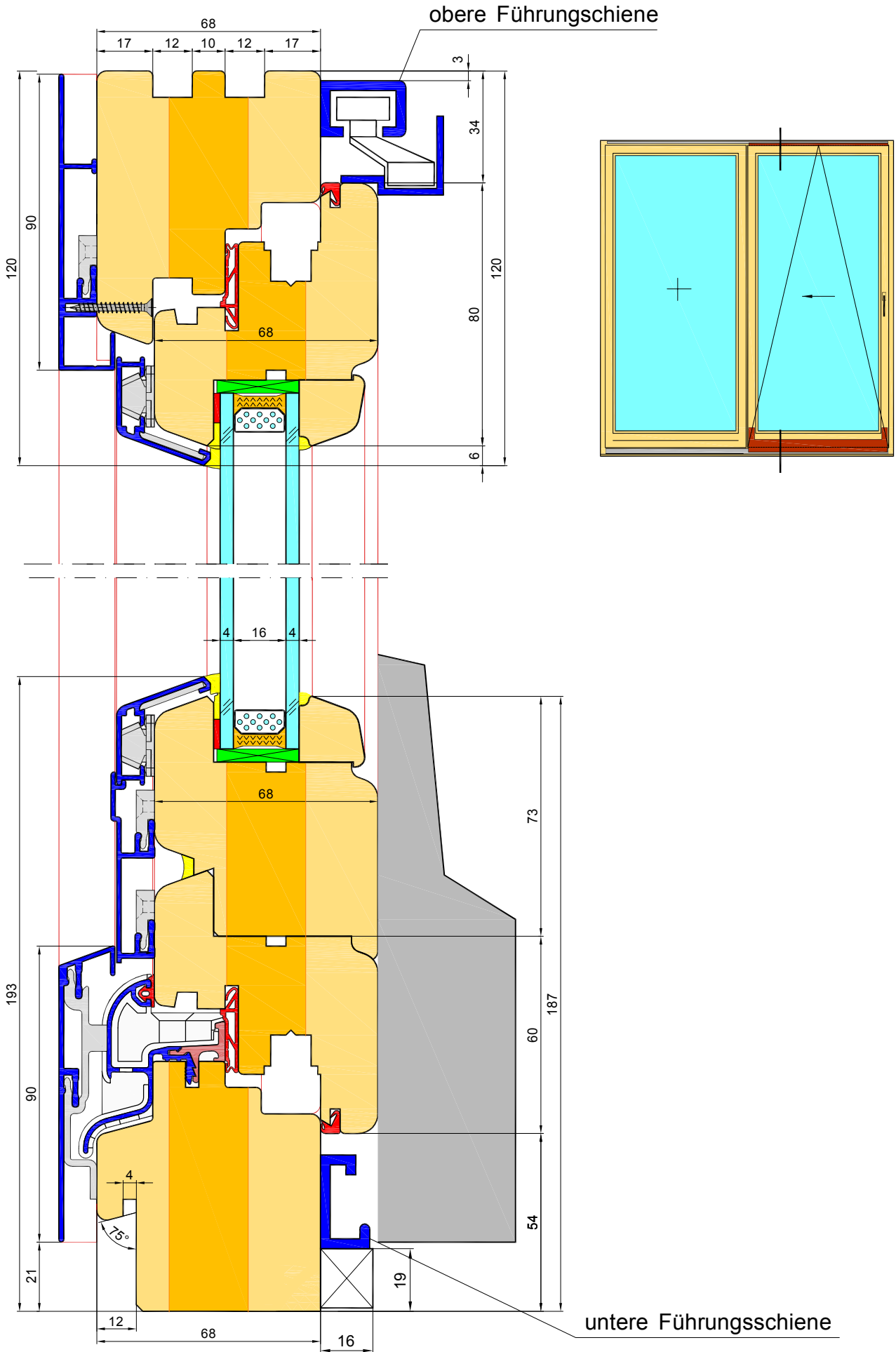

STYLE 68 ALU - 2-fach Verglassung

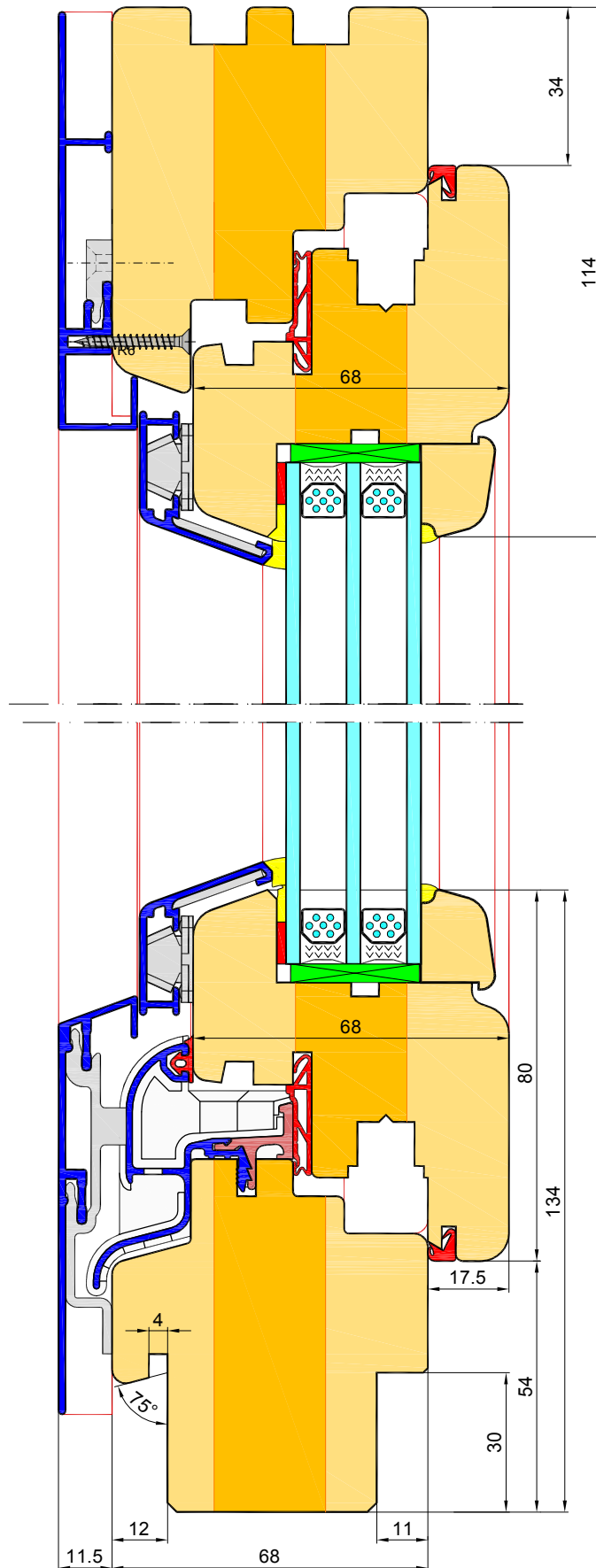

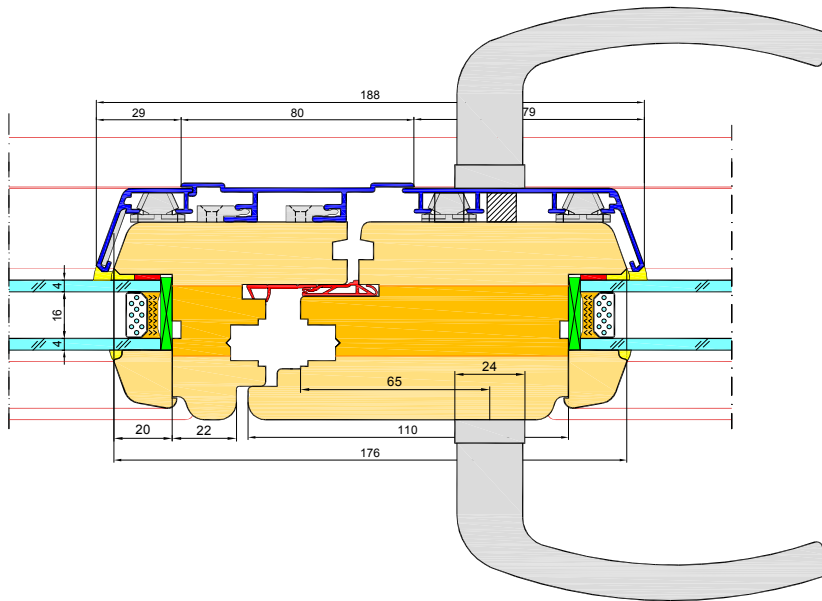

2 fl. Balkontür mit Stulp

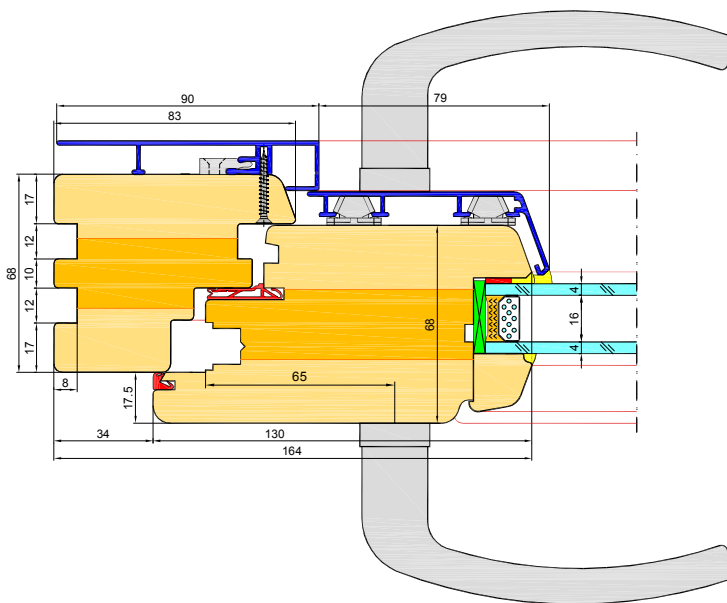

1 fl. Balkontür

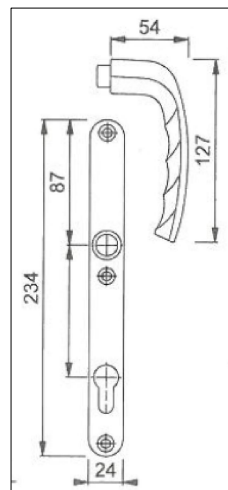

Kopplung 90°

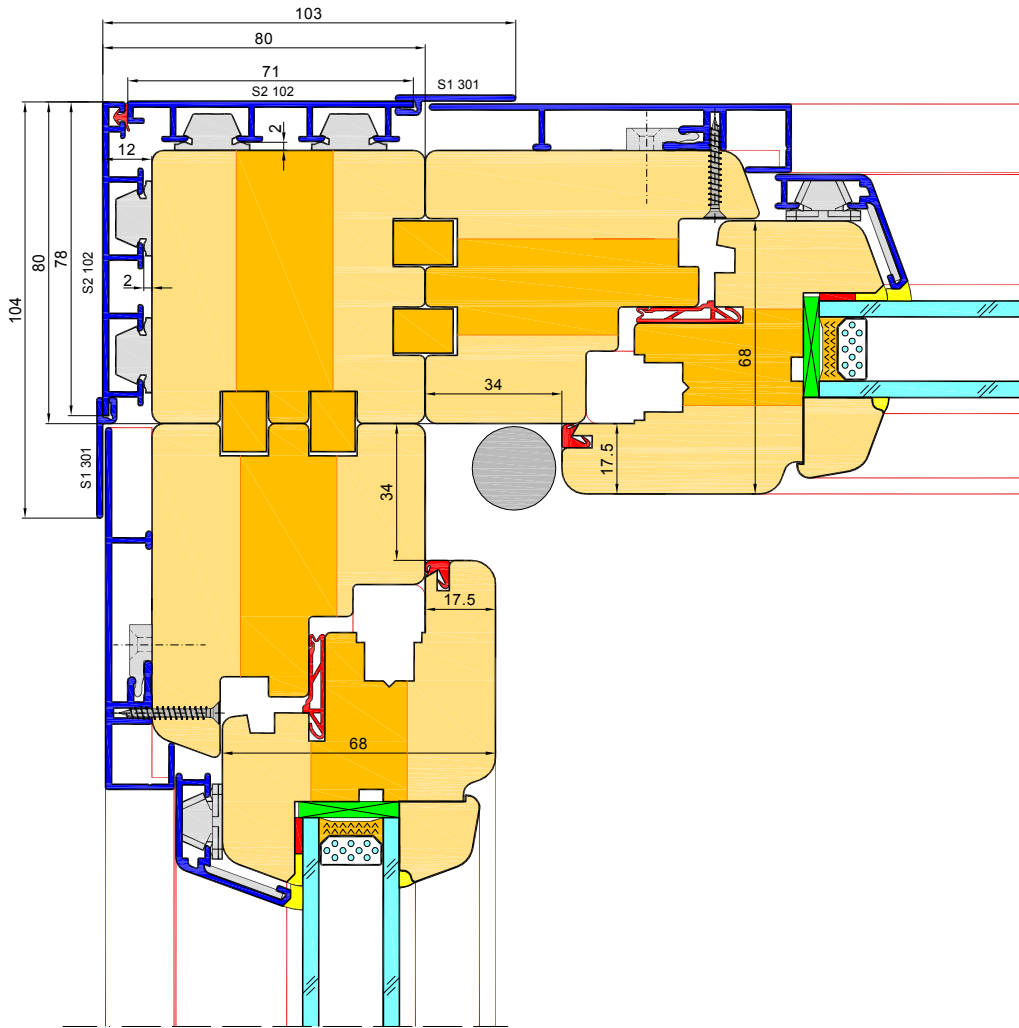

Kopplung 135°

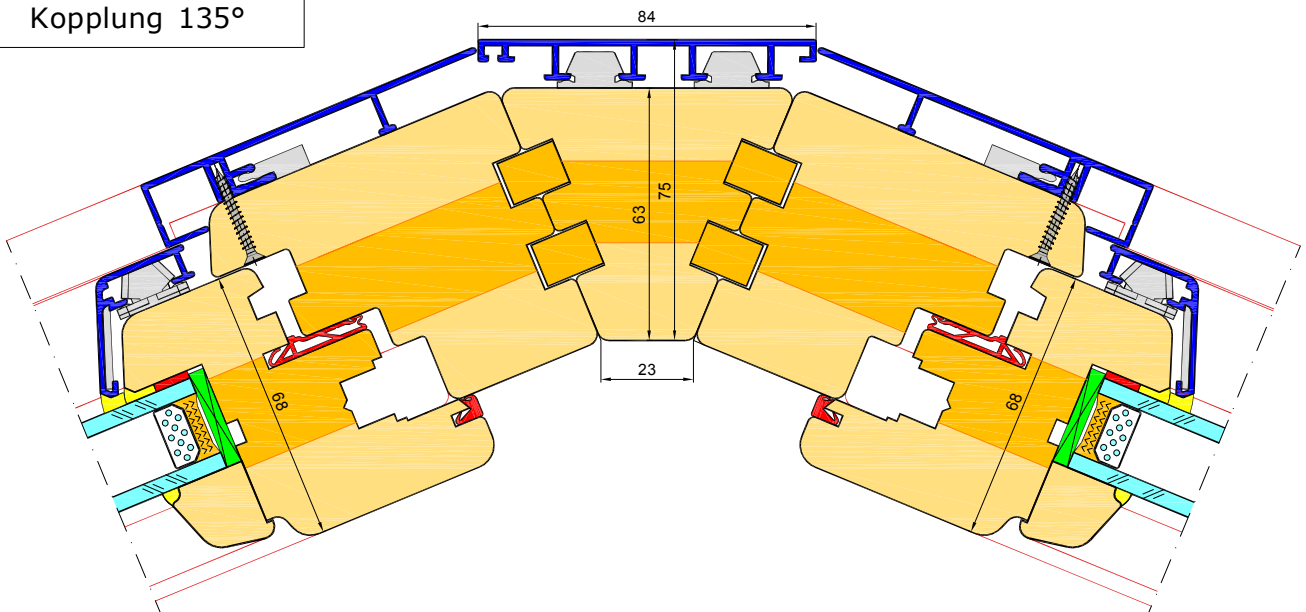

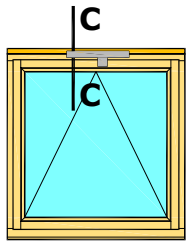

Verbreiterung des
Sturzes minimum 20 mm

Stromversorgung
- Leitung

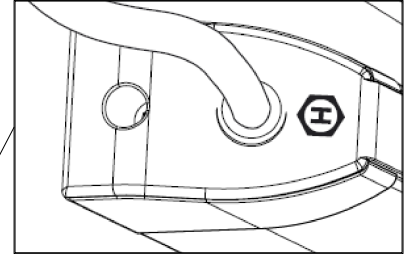
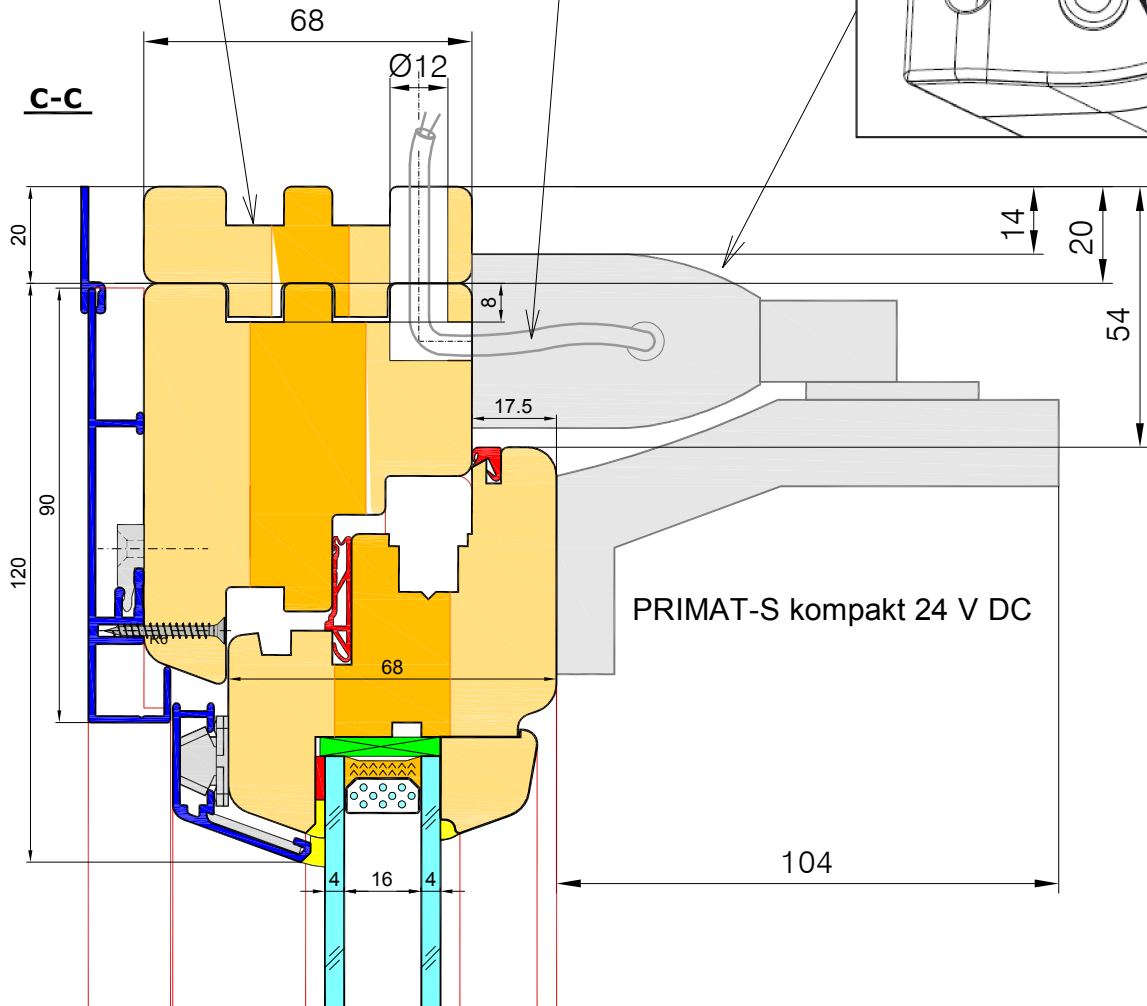

zulässiges Gewicht der Flügel
50kg

